

Contribution of Earth and Space Science Online Course to Development of TPACK for Prospective Science Teachers in Primary Education

Diki Rukmana¹, Sri Lestari Handayani

Faculty of Teacher Training and Education, Universitas Muhammadiyah Prof. Dr Hamka (UHAMKA),
Jakarta, Indonesia

¹Corresponding author: dikirukmana@uhamka.ac.id

Abstract

Purpose: Prospective teacher educations has the challenge of being able to equip teachers with the skills to manage classroom learning by utilizing various technological resources. One approach that can be taken is to design lectures who can contribute to the development of TPACK. This study examines the suitability of online learning practices in earth and space science courses for the development of TPACK prospective for prospective science teachers in primary education.

Methodology: The survey research was conducted on 68 students who took Earth and Space Science courses online in the even semester of 2019/2020. Factor Analysis and Structural Equation Modelling (SEM) were conducted to analyse the validity of the instrument and testing of hypotheses.

Results: The result of the factor analysis showed that the 27 instruments used had sufficient correlation to confirm the structure of each variable. SEM analysis results show that online learning that has been implemented has a positive and significant effect on the development of pre-service teacher TPACK.

Applications/Originality/Value: These findings are a reference for those who intend to develop an online learning framework that can support the development of TPACK for prospective teachers.

Introduction

Learning that occurs in schools today has experienced a shift from conventional learning to ICT-based learning. Preparing teacher candidates to be able to integrate technology effectively in their future classrooms is considered an indispensable component of teacher education programs worldwide (Drummond & Sweeney, 2017). One learning approach that can integrate technology into learning is the TPACK (Technology, Pedagogical Content knowledge) framework which emphasizes the integration of technology, pedagogy and content in learning. This approach requires teachers to be able to involve the use of technology to create a learning environment, but still pay attention to the pedagogical elements inherent in learning content when the content is taught to students.

One of the important roles of teachers in learning is the ability of a teacher to keep up with technological developments and have good ICT literacy in order to be able to fully support online learning. Without good mastery of ICT, the role of teachers in facilitating online learning activities that access knowledge from various digital content sources will experience difficulties. Primary school teacher education study programs have the responsibility of producing primary school teacher graduates who are able to answer these challenges. One way that can be done is to design a lecture program that equips prospective teachers in integrating technology into learning.

Earth and space science lectures given to the primary school teacher education study program are a potential course for developing TPACK abilities, the online learning policy implemented by the government on the covid-19 mass requires lecturers to restructure the lecture process from previously carried out offline to online lectures and the resulting impact on the TPACK development process that had previously been carried out in offline learning. Based on this, the question of this research is whether online earth and space science courses can positively and significantly support the development of TPACK for prospective science teacher in primary education?

Literature Review

Technological Pedagogical Content Knowledge (TPACK)

TPACK is a theoretical framework for describing and studying teacher professional knowledge. TPACK consists of three main components, namely: technological knowledge (TK), pedagogical knowledge (PK) and content knowledge (Koehler et al., 2013). TPACK was originally developed by Shulman's who described PCK (Pedagogical and Content Knowledge) (Shulman, 1986, 1987). The TPACK model is an extension of the PCK concept by adding technology as a special type of teacher knowledge.

TPACK is a basic foundation of effective technology, knowledge of what makes a concept or easy to learn and how technology can help solve some of the problems that make students; knowledge of how technology can be used to develop existing knowledge and to develop new epistemologies or destroy old epistemologies (Mishra & Koehler, 2006). TPACK is a strategic way of thinking when involved in planning, organizing specific content for specific student needs and specific classroom situations while considering many twenty-first century technologies with the potential to support student learning. (Niess, 2008). TPACK is specifically referred to as contextual knowledge that integrates technology and pedagogy on specific knowledge (Angeli & Valanides, 2009; Archambault & Barnett, 2010). Teachers need a special form of professional knowledge called pedagogical content knowledge technology (TPACK) to support ICT integration (Mishra & Koehler, 2006).

In the last decade, researchers have extensively used the TPACK to guide the design of teacher education programs. TPACK is accepted as an important framework for determining how well teachers integrate technology into their classrooms (Baran et al., 2019). Because the understanding of TPACK is hidden in the spontaneous actions of teachers, many studies on TPACK call for the use of new approaches to examining TPACK in practice (Chai et al., 2013). One approach is the conceptualization of teacher practical knowledge which places TPACK on the teacher's teaching practice and experience (Yeh et al., 2014). Then, the most common measurement tool for investigating TPACK is the self-report survey, which provides data on self-efficacy, beliefs, and attitudes of prospective teachers (Baran et al., 2019).

Earth and Space Online Course Based on TPACK Framework

Earth and space science is one of the science courses held in the primary school teacher education study program. The main purpose of holding this course is to provide a comprehensive understanding of the concept of earth and space sciences as well as a means of training for prospective teachers to design earth and space science learning for elementary school learning. This course discusses the basic concepts of the earth including the lithosphere, hydrosphere and atmosphere, natural resources, and terrestrial natural disasters. It also discusses the basic concepts of space including galaxies, stars, planets, satellites, comets, asteroids and other celestial bodies and phenomena related to them.

In this course, there are many discussed concepts related to natural phenomena which in real conditions are difficult to find directly, either because of the time cycle constraints the phenomenon appears or due to limited observations. So in learning earth and space science, videos, simulations, animation, computer modeling and other digital media are often used to study natural phenomena that are not directly accessible to observations. With a lecture system that involves a lot of ICT, this course is very potential to then equip prospective teachers with ICT integration skills into learning by referring to the TPACK framework.

Previous research has developed a teacher education model to prepare prospective teachers to be able to integrate technology in their future classrooms (Tondeur et al., 2016). According to the findings of this review, there are 6 strategies that can be used by teacher education to develop TPACK.

1. Educators must provide useful examples as role models and important motivators for the development of TPACK prospective teachers
2. Prospective teachers need to observe, discuss and reflect collaboratively on the successful use of technology in terms of the benefits, values and appropriateness of using technology (Lim & Chan, 2007)
3. Prospective teachers need to be given the opportunity to learn about technology integration by evaluating and designing curriculum materials (Angeli & Valanides, 2009).

4. Collaboration with peers seems to provide a low-threat learning environment for prospective teachers, thereby reducing anxiety and avoiding failure (Angeli & Valanides, 2009).
5. Teacher candidates need to apply their knowledge of educational technology in authentic settings
6. Ongoing and process-oriented feedback is useful for building the ability of prospective teachers to use technology in the classroom (Banas & York, 2014).

Based on the TPACK-oriented teacher candidate education guidelines as previously explained, before the learning from home policy was implemented during the Covid-19 pandemic, face-to-face earth and space science courses focused on developing TPACK for prospective teachers. Several aspects contained in lectures that show support for the development of TPACK prospective teachers include:

1. In some initial lectures, prospective teachers are introduced to the content of the Earth and space science curriculum for learning in elementary schools
2. In the next several lectures, prospective teachers were introduced to digital applications, web, games and other ICT devices that could provide technological support for learning earth and space science.
3. In the next few lectures, prospective teachers were introduced to 21st century pedagogical skills that can be used in learning in elementary schools.
4. In the next few lectures, prospective teachers are given project assignments to design an earth science and space science learning activity for elementary school students by taking into account the suitability of content, 21st century pedagogical skills and the use of ICT.
5. The remainder of the lecture is used for micro teaching, where prospective teachers act as real teachers to realize the learning activities they have designed.
6. Lecturers and other prospective teachers will provide an evaluation of the micro teaching activity.

After the study from home policy was implemented, the lecture process was carried out online using several video conference applications. the practice of micro teaching recovery based on TPACK development is still maintained, but there are adjustments in several aspects, including:

1. 21st century pedagogic skills were introduced to teachers who were previously aimed at designing offline learning activities, then expanded to designing online learning activities.
2. ICT integration, which previously used to be the use of video, animation, web and computer modeling applications, is also extended to the aspects of using online distance learning applications.
3. micro teaching activities that were previously designed for face-to-face activities are extended to online distance learning activities.

Figure 1 shows how the process of transforming earth and space science lectures based on the TPACK framework from offline learning to online learning. Through this research, it will be tested whether the online lecture practice that is designed is able to contribute to the development of TPACK.

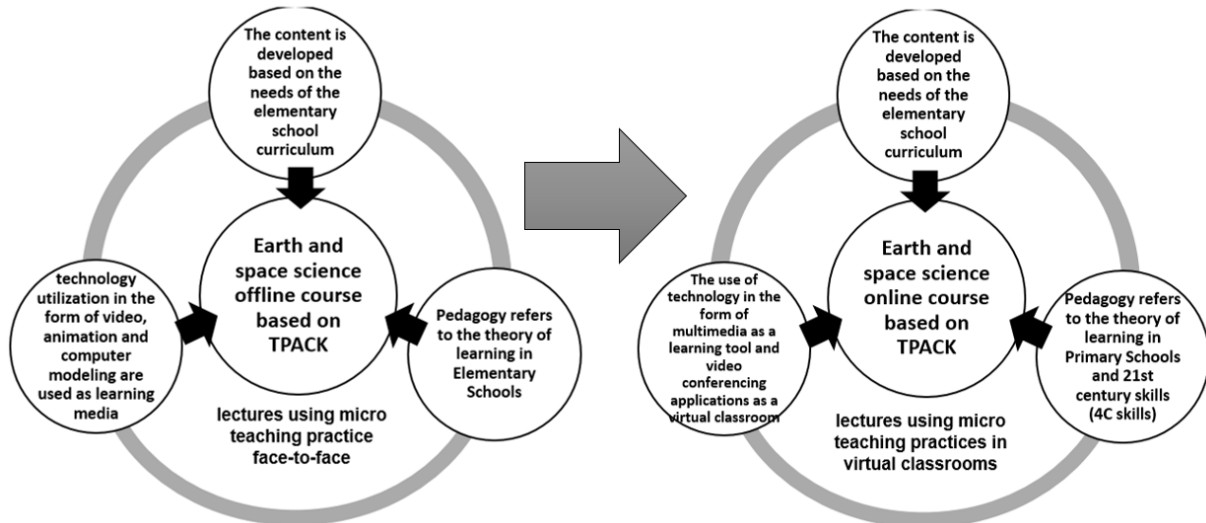

Figure 1: The transformation of earth and space science lectures based on the TPACK framework from offline learning to online learning.

Method

This study used a survey research design. It is a quantitative research procedure that is carried out to describe the attitudes, behavior and characteristics of a population. The type of survey used was a survey with a cross-sectional design, in which the researcher collected data at a point in time (Creswell, 2012). In this study, the aspects that will be measured through survey instruments include the quality of online Earth and space science lectures, technology knowledge, content knowledge, pedagogical knowledge and TPACK.

Proposed Conceptual Framework

The proposed research model shows the direction of the hypothesized relationship between variables as shown in Figure 2. Based on the Proposed Conceptual Framework shown in Figure 1, the hypotheses to be tested through SEM analysis in this study are as follows:

- H1 : Earth and space science online lectures have a positive and significant effect on the development of pedagogical knowledge.
- H2 : Earth and space science online lectures have a positive and significant effect on the development of content knowledge
- H3 : Earth and space science online lectures positively and significantly affect the development of technological knowledge.
- H4 : Online lectures on earth and space science, through the development of pedagogical knowledge, content and technology have a positive and significant effect on the development of TPACK

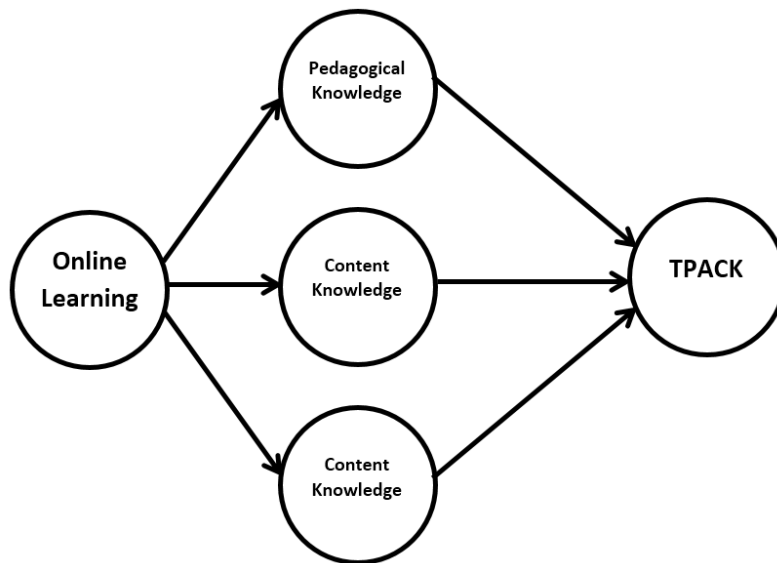

Figure 2. Proposed Conceptual Framework

Participants

The subjects of this study were 68 students who took Earth and Space Science courses online in the even semester of 2019/2020, consisting of 7 (10.29%) male and 61 (89.71%) female.

Measures

In this study, an instrument in the form of a survey questionnaire was used. This survey instrument is used to explore quantitative data on the variables of Online Learning (OL) Pedagogical Knowledge (PK), Content Knowledge (CK), Technology Knowledge (TK) and Technology Pedagogical Content Knowledge (TPACK). The five variables are then broken down into 27 survey instruments using a 1-6 Likert scale. The indicators for the 27 instrument items can be seen in the **table 1**

Table 1. Research variable indicators.

Variable	Item Code	Item Indicator
Online Learning Quality (OL)	OL1	Contribution of online lectures to the development of pedagogical knowledge
	OL2	Contribution of online lectures to the development of content knowledge
	OL2	Contribution of online lectures to the development of technological knowledge
Pedagogical Knowledge (PK)	PK1	Learning strategies to guide students in group discussions
	PK2	Learning strategies to train students' critical thinking skills
	PK3	Learning strategies that can guide students to learn independently
	PK4	Learning strategies that can practice students' reflective thinking skills
	PK5	Learning strategies that can practice student problem solving skills
	PK6	Learning strategies that can train students' creative skills
Content Knowledge (CK)	CK1	Knowledge to develop earth and space science content
	CK2	Knowledge of basic theories and concepts of earth and space sciences
	CK3	Knowledge of the history and development of important theories in the earth and space sciences
	CK4	Knowledge of the latest research in earth and space sciences.
	CK5	Knowledge of the application of earth and space science in everyday life.
	CK6	Knowledge of developing simple practical skills in earth and space sciences

Variable	Item Code	Item Indicator
Technology Knowledge (TK)	TK1	Knowledge of the right types of technology used in the learning process
	TK2	Knowledge of the latest technology that can be used to communicate with many people together
	TK3	Knowledge of applications that can be used to create and process images
	TK4	Knowledge of applications that can be used to create and process videos
	TK5	Knowledge of applications that can be used to create and process animation
	TK6	Knowledge of web sites that can be visited and studied to improve one's abilities in the field of technology
Technology Pedagogical Content Knowledge (TPACK)	TPACK1	Knowing how to use ICT in science learning to facilitate students so they can practice reflective thinking skills
	TPACK2	Knowing how to use ICT in science learning to facilitate students to learn independently
	TPACK3	Knowing how to use ICT in science learning to facilitate student problem solving activities in groups
	TPACK4	Know how to use ICT in science learning to facilitate students so they can practice creative thinking skills
	TPACK5	Knowing how to use ICT in science learning that can facilitate students to work in groups
	TPACK6	Knowing how to use ICT in science learning to facilitate students to practice critical thinking skills.

Data Analysis

To test the validity of the research instrument and to test the hypothesis of the research model, factor analysis and PLS (Partial Least Squares) SEM-VB (Structural Equation Modeling-Variance Based) were carried out using SmartPLS 3.0 software (Ringle et al., 2015). The main reason for choosing SEM as a statistical method for this research is because SEM can perform analysis simultaneously and has more accurate predictions (Isaac et al., 2016, 2017a, 2017b).

Result

Descriptive Statistics

The data that will be displayed in this descriptive statistic include the maximum score and minimum score, average, standard error, curve and skewness as shown in **table 2**.

Table 2. Descriptive Statistics.

Construct	Item Code	No	Min	Max	Mean	Stdev	Kurt.	Skew.
Online Learning Quality (OL)	OL1	1	2	6	4.318	0.973	-0.352	0.099
	OL2	2	1	6	3.894	1.006	0.766	-0.418
	OL3	3	2	6	4.188	0.888	-0.085	0.027
Pedagogical Knowledge (PK)	PK1	4	1	6	3.812	1.193	-1.032	-0.346
	PK2	5	1	5	3.459	1.232	-0.893	-0.326
	PK3	6	1	6	3.965	1.111	-0.179	-0.663
	PK4	7	1	6	3.871	1.156	-0.244	-0.626
	PK5	8	1	6	3.718	1.102	-0.526	-0.435
	PK6	9	1	6	3.753	1.147	-0.546	-0.261
Content Knowledge (CK)	CK1	10	1	6	3.835	1.206	-0.268	-0.454
	CK2	11	1	6	3.494	1.154	-0.614	-0.172

Construct	Item Code	No	Min	Max	Mean	Stdev	Kurt.	Skew.
Technology Knowledge (TK)	CK3	12	1	6	4.153	1.101	-0.066	-0.580
	CK4	13	1	6	4.329	1.152	0.079	-0.678
	CK5	14	2	6	4.259	1.118	-0.422	-0.428
	CK6	15	1	6	4.141	1.160	0.081	-0.650
	TK1	16	1	6	4.212	1.199	0.430	-0.795
	TK2	17	1	6	4.447	1.153	0.419	-0.806
	TK3	18	1	6	3.976	1.255	0.157	-0.754
	TK4	19	1	6	4.153	1.163	0.450	-0.762
	TK5	20	1	6	3.424	1.141	-0.243	-0.122
Technology Pedagogical Content Knowledge (TPACK)	TPACK1	22	1	6	3.776	1.240	-0.345	-0.279
	TPACK2	23	1	6	3.671	1.192	-0.607	-0.224
	TPACK3	24	1	6	3.929	1.166	-0.322	-0.313
	TPACK4	25	1	6	3.741	1.209	-0.282	-0.257
	TPACK5	26	1	6	3.765	1.025	-0.437	-0.377
	TPACK6	27	1	6	3.694	1.074	-0.589	-0.170

A data is said to be normally distributed when the Kurtosis value is in the range -7 to 7 and the Skewness value is in the range -2 to 2 (Curran et al., 1996; West et al., 1995). Based on table 1, all survey instrument items are normally distributed.

Measurement Model

Based on the results of the factor analysis of the survey instruments used by using SmartPLS, the results are obtained as shown in the structure of the measurement model assessment in **figure 3**.

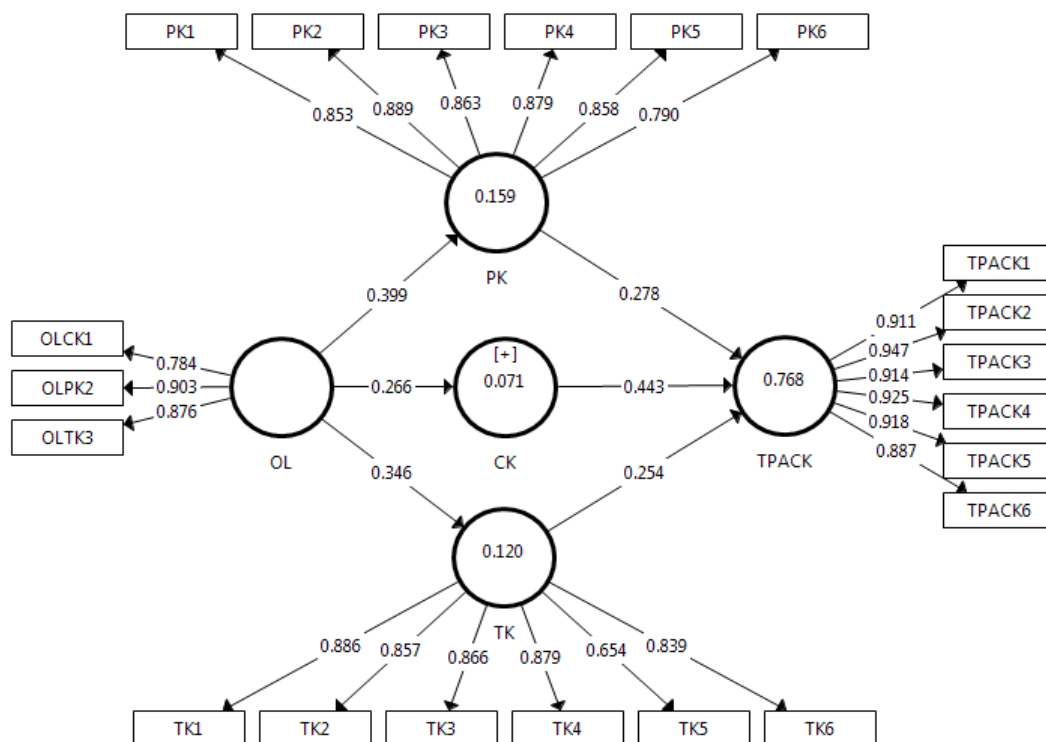

Figure 3. Measurement Model Assessment

To test the construct validity of the research instrument, Confirmatory Factor Analysis (CFA) was used, which consists of convergent validity and discriminant validity. Convergent validity is a measure of the extent to which several specific construct variables gather together and share the same proportion to form high variance (Hair et al., 2014). Convergent validity measures can be seen from the loading factor, average variance extracted (AVE) and composite reliability (CR).

Table 3. Convergent Validity

Construct	Item Code	Outer Loading	AVE	CR	Cronbach's Alpha
Online Learning Quality (OL)	OL1	0.784	0.733	0.891	0.815
	OL2	0.903			
	OL3	0.876			
Pedagogical Knowledge (PK)	PK1	0.853	0.696	0.943	0.927
	PK2	0.889			
	PK3	0.863			
	PK4	0.879			
	PK5	0.858			
	PK6	0.790			
Content Knowledge (CK)	CK1	0.875	0.804	0.961	0.951
	CK2	0.809			
	CK3	0.933			
	CK4	0.924			
	CK5	0.917			
	CK6	0.916			
Technology Knowledge (TK)	TK1	0.886	0.702	0.931	0.911
	TK2	0.857			
	TK3	0.866			
	TK4	0.879			
	TK5	0.654			
	TK6	0.839			
Technology Pedagogical Content Knowledge (TPACK)	TPACK1	0.911	0.841	0.969	0.962
	TPACK2	0.947			
	TPACK3	0.914			
	TPACK4	0.925			
	TPACK5	0.918			
	TPACK6	0.887			

Based on table 3, there are 26 construct items that have an outer loading value ranging from 0.784 to 0.947 which exceeds the proposed value of 0.7 (Hair et al., 2017), while 1 other item has an outer loading value of 0.654 which can still be accepted provided that the AVE value is greater than 0.5 (Hair et al., 2017). The AVE value shows a variation in the value between 0.696 to 0.841 which exceeds the proposed value of 0.50 (Fornell & Larcker, 1981; Hair et al., 2017). Then the CR value ranges from 0.891 to 0.969, which also exceeds the proposed value of 0.7 (Gefen et al., 2000; Kline, 2011). Based on these results, it can be seen that all of the convergent validity indicators have met the requirements because the loading value, AVE, CR and Cronbach alpha have exceeded all the proposed parameter values, so it can be concluded that all construct items are valid instruments in constructing each latent variable.

Another measure that shows construct validity is discriminant validity, which is a measure that shows the extent to which a construct is completely different from other constructs (Hair et al., 2010). Discriminant

validity requires that a construct is not too highly correlated with other constructs (Campbell, 1960), because when there is a high correlation between two variables, the researcher cannot confirm that the hypothesized structural pathway actually occurs (Farrell, 2010).

Table 4. Discriminant Validity: Heterotrait-Monotrait ratio

	OL	PK	CK	TK	TPACK
OL					
PK	0.457				
CK	0.301	0.745			
TK	0.705	0.373	0.699		
TPACK	0.525	0.829	0.838	0.806	

There are two measures that become indicators of the fulfillment of discriminant validity, namely the Heterotrait-Monotrait ratio and the Fornell & Larcker Criterion. The heterotrait-monotrait ratio is a value that represents the average heterotrait-heteromethod relative to the average monotrait-heteromethod appearance (Hair et al., 2017; Henseler et al., 2014). Based on table 4, the Heterotrait-Monotrait ratio values are in the range 0.301 to 0.838 where the value is <0.85 which is the threshold value for discriminant validity (Kline, 2011).

Table 5. Discriminant Validity: Fornell & Larcker Criterion

	OL	PK	CK	TK	TPACK
OL	0.856				
PK	0.399	0.856			
CK	0.266	0.700	0.897		
TK	0.346	0.781	0.651	0.834	
TPACK	0.464	0.787	0.803	0.760	0.917

Table 5 shows the Fornell & Larcker Criterion values where the values shown on the thick diagonal are the root of the AVE value, while the remainder is the correlation coefficient (r). The condition for fulfilling the Fornell & Larcker Criterion value is when the AVE square root value of the latent variable must be higher than the correlation between the latent variable and all other variables (Chin, 1998; Fornell & Larcker, 1981). Based on table 4, the AVE root value (thick diagonal) shows a higher value than the other values, so it can be concluded that the discriminant validity with the Fornell & Larcker Criterion indicator is also fulfilled.

Testing the Hypothesized Models

To test the hypothesized structural model, standard values of beta (β), R^2 , and t-values were used through the bootstrap procedure with a 5.000 repeat sample (Hair et al., 2017).

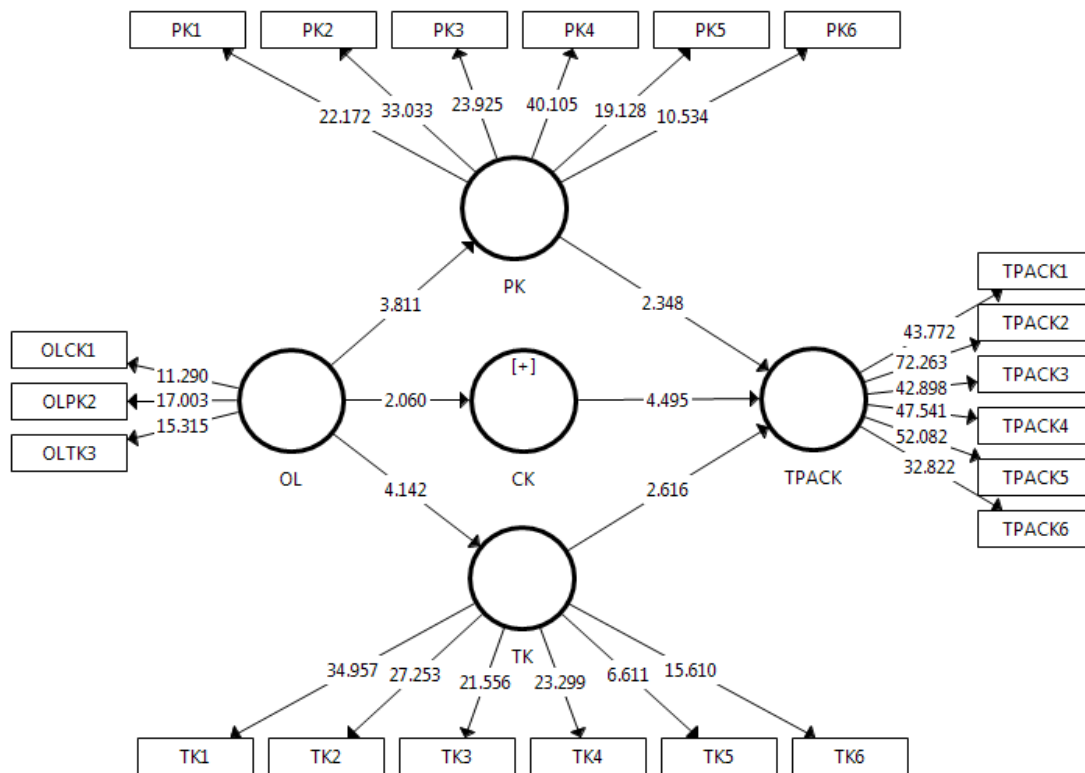

Figure 4. Structural Model Assessment

Figure 4 and Table 6 illustrate the hypothesized structural model test results. Based on the test results, the results show that online lectures on Earth and Space Sciences directly have a positive and significant effect on pedagogical knowledge ($\beta = 0.399$, $t = 3.811$), content knowledge ($\beta = 0.266$, $t = 2.060$) and technological knowledge ($\beta = 0.346$, $t = 4.142$) which then the three knowledge has a positive and significant effect on the ability of TPACK prospective teachers with ($\beta = 0.278$, $t = 2.348$), ($\beta = 0.443$, $t = 4.495$) and ($\beta = 0.254$, $t = 2.616$). Then the indirect effect of online learning on TPACK ability also has a positive and significant effect with ($\beta = 0.317$, $t = 4.446$).

Table 6. Structural Model Assessment.

Hypothesis	Path	Std. Beta	Std. Error	t-value	Bias	Confidence interval		Decision	R ²
						5.00%	95.00%		
H1	OL -> PK	0.399	0.105	3.811	0.015	0.201	0.548	Supported	
H2	OL -> CK	0.266	0.129	2.060	0.016	0.030	0.457	Supported	
H3	OL -> TK	0.346	0.084	4.142	0.021	0.170	0.456	Supported	
H4	PK -> TPACK	0.278	0.118	2.348	0.005	0.096	0.485	Supported	0.768
H5	CK -> TPACK	0.443	0.099	4.495	-0.003	0.285	0.612	Supported	
H6	TK -> TPACK	0.254	0.097	2.616	-0.001	0.105	0.424	Supported	
H7	OL -> PK,CK,TK -> TPACK	0.317	0.096	3.306	0.023	0.123	0.446	Supported	

Note: $p < 0.05$

Based on the R2 value, it can be concluded that pedagogic knowledge, content knowledge and technological knowledge possessed by prospective teachers affect the TPACK ability of 76.8%, this influence is in the high category (Cohen, 1988).

Discussion

The Effect of Online Lectures on the three basic components of TPACK

With the enactment of the learning from home policy during the Covid-19 pandemic in Indonesia, an educator, including those in higher education, in a short preparation time must change all offline lecturing practices to online lectures. The main focus of this research is to ensure that the practice of online lectures carried out in Earth and space science courses can still contribute positively to the competence of prospective teachers, especially in the TPACK aspects that have previously been developed in offline lectures.

As we know that TPACK is built from three main knowledge components, namely technological knowledge, pedagogical knowledge and content knowledge. In the practice of online lectures carried out in earth and space science courses, they focus on improving these three components. Based on simple logical reasons, when the three components can be improved in a lecture, it is expected that they will contribute to the further development of TPACK.

If we look at the teacher candidates' self-assessment scores on the three basic components of TPACK, the average score for Pedagogical knowledge is 3,763, content knowledge is 4,035 and technology knowledge is 4,075. Based on these three values, it is clear that online lectures carried out in Earth and Space Sciences courses are still low in developing pedagogic knowledge. We realize this because the online learning environment that we built in our video conferencing application is quite difficult to use to build pedagogic knowledge, especially those that are specific to pedagogic skills needed by teachers in the 21st century (critical thinking, creative, communication and collaboration). If in offline learning a lecturer can freely design a lecture that can accommodate 21st century skills, it is different in an online learning environment where each student learns independently in their respective homes and interpersonal communication interactions are not as free as in offline learning.

However, apart from the average self-assessment score of prospective teachers on each aspect of the TPACK constituent, the hypothesis testing results show that the proposed conceptual model is acceptable. This shows that the practice of online recovery carried out in the Earth and space science courses positively and significantly influences the development of pedagogic knowledge, content and technology. With the acceptance of this conceptual model, the online lecture practice that has been designed by lecturers in the earth and space science course contributes to the development of the three components that make up TPACK. In the next stage, it remains how to improve the practice of online lectures so that they can provide better results in developing the three components of TACK.

The Effect of Online Course on the Development of TPACK

In this study, the contribution of online lectures to the development of TPACK for prospective teachers will be explored through the analysis of Structural Equation Model (SEM). Currently, there are only a few studies that can map the relationship between the seven factors through structural equation modeling (SEM) (Chai et al., 2013; Koh et al., 2013). One study reported that CK and PCK did not predict teacher TPACK positively, while other factors predicted TPACK positively (Koh et al., 2013). Other research shows that the direct positive predictors of the TPACK of pre-service teachers are TCK, PCK and TPK, with TK, CK, and PK only having an indirect effect (Chai et al., 2013). Other studies reported that PK, CK, TK and PCK did not predict TPACK positively, while other factors had a positive effect (Dong et al., 2015). The difference in the results from these studies suggests that the mapping of the model structure of the factors forming TPACK under various conditions may not be the same, which implies that educators need to understand the distinguishing effects of TPACK development in different groups.

This study tries to focus on the mapping of the structure of the model of the effect of online lectures on TPACK's ability development by placing the three basic components of TPACK development (PK, CK and TK) as a mediator (without prejudice to the role of PCK, TPK and TCK). The results of the analysis show that indirectly the practice of online lectures carried out in the basic concepts of earth and space contributed to the development of TPACK, where the three basic components of TPACK forming a role as a mediator. These results indicate that online lectures conducted on the basic concepts of earth and space do not only have a positive and significant effect on the three components of TPACK partially, the practice of online lectures that

is carried out also contributes to integrating the three basic components in the form of the TPACK framework. In this case, the prospective teacher gives an assessment of himself that the online lectures that have been carried out, on the one hand have a direct contribution to the development of the three basic components of TPACK, on the other hand have an indirect effect on the development of TAPCK.

Conclusions and Implications

This study examines the suitability of online learning practices in earth and space science courses for the development of TPACK for prospective teachers. The results show that the practice of online learning in earth and space science courses has contributed to the development of TPACK for prospective teachers with three aspects of basic knowledge forming TPACK acting as a moderator.

Although this study succeeds in providing a conceptual model which shows that the practice of online lectures in earth and space science courses contributes to the development of TPACK for prospective teachers, this study also has limitations in not disclosing the contribution of the three secondary factors (PCK, TPK and TCK) forming TPACK as a secondary mediator. In the future, further research is needed to explore these things so that they can make a significant contribution to the achievement of current research results.

However, despite the various limitations of the research, this finding is quite encouraging, because it has succeeded in providing an overview of the suitability of online learning practices in earth and space science courses for the development of TPACK for prospective teachers. The findings of this study can provide important insights for lecturers and policy makers on how to design better earth and space science online courses in supporting the development of a better TPACK.

References

- Angeli, C., & Valanides, N. (2009). Epistemological and methodological issues for the conceptualization, development, and assessment of ICT-TPCK: Advances in technological pedagogical content knowledge (TPCK). *Computers and Education*, 52(1), 154–168. <https://doi.org/10.1016/j.compedu.2008.07.006>
- Archambault, L. M., & Barnett, J. H. (2010). Revisiting technological pedagogical content knowledge: Exploring the TPACK framework. *Computers and Education*, 55(4), 1656–1662. <https://doi.org/10.1016/j.compedu.2010.07.009>
- Banas, J. R., & York, C. S. (2014). Authentic learning exercises as a means to influence preservice teachers' technology integration self-efficacy and intentions to integrate technology. *Australasian Journal of Educational Technology*, 30(6), 728–746. <https://doi.org/10.14742/ajet.362>
- Baran, E., Canbazoglu Bilici, S., Albayrak Sari, A., & Tondeur, J. (2019). Investigating the impact of teacher education strategies on preservice teachers' TPACK. *British Journal of Educational Technology*, 50(1), 357–370. <https://doi.org/10.1111/bjet.12565>
- Campbell, D. T. (1960). Recommendations for APA test standards regarding construct, trait, or discriminant validity. *American Psychologist*, 15(8), 546–553. <https://doi.org/10.1037/h0048255>
- Chai, C. S., Ng, E. M. W., Li, W., Hong, H. Y., & Koh, J. H. L. (2013). Validating and modelling technological pedagogical content knowledge framework among asian preservice teachers. *Australasian Journal of Educational Technology*, 29(1), 41–53. <https://doi.org/10.14742/ajet.174>
- Chin, W. W. (1998). Issues and opinion on structural equation modeling. *MIS Quarterly*, 22(1), 7–16.
- Cohen, J. (1988). *Statistical Power Analysis for the Behavioral Sciences* (2nd ed.). Lawrence Erlbaum Associates, Publishers.
- Creswell, J. W. (2012). *Educational RESEARCH: Planning, Conducting, and Evaluating Quantitative and Qualitative Research* (4th ed.). Pearson.
- Curran, P. J., West, S. G., & Finch, J. F. (1996). The Robustness of Test Statistics to Nonnormality and Specification Error in Confirmatory Factor Analysis. *Psychological Methods*, 1(1), 16–29. <https://doi.org/10.1037/1082-989X.1.1.16>

- Dong, Y., Chai, C. S., Sang, G. Y., Koh, J. H. L., & Tsai, C. C. (2015). Exploring the profiles and interplays of pre-service and in-service teachers' technological pedagogical content knowledge (TPACK) in China. *Educational Technology and Society, 18*(1), 158–169.
- Drummond, A., & Sweeney, T. (2017). Can an objective measure of technological pedagogical content knowledge (TPACK) supplement existing TPACK measures? *British Journal of Educational Technology, 48*(4), 928–939. <https://doi.org/10.1111/bjet.12473>
- Farrell, A. M. (2010). Insufficient discriminant validity: A comment on Bove, Pervan, Beatty, and Shiu (2009). *Journal of Business Research, 63*(3), 324–327. <https://doi.org/10.1016/j.jbusres.2009.05.003>
- Fornell, C., & Larcker, D. F. (1981). Evaluating Structural Equation Models with Unobservable Variables and Measurement Error. *Journal of Marketing Research, 18*(1), 39–50. <https://doi.org/10.2307/3151312>
- Gefen, D., Straub, D., & Boudreau, M.-C. (2000). Structural Equation Modeling and Regression: Guidelines for Research Practice. *Communications of the Association for Information Systems, 4*(October). <https://doi.org/10.17705/1cais.00407>
- Hair, J. F., Black, W. C., Babin, B. J., & Anderson, R. E. (2010). *Multivariate data analysis* (7th ed.). Prentice Hall.
- Hair, J. F., Hult, G. T. M., Ringle, C. M., & Sastedt, M. (2017). *A Primer on Partial Least Squares Structural Equation Modeling (PLS-SEM)* (2nd ed.). Sage, Thousand Oaks, CA.
- Hair, J. F., Sarstedt, M., Hopkins, L., & Kuppelwieser, V. G. (2014). Partial least squares structural equation modeling (PLS-SEM): An emerging tool in business research. *European Business Review, 26*(2), 106–121. <https://doi.org/10.1108/EBR-10-2013-0128>
- Henseler, J., Ringle, C. M., & Sarstedt, M. (2014). A new criterion for assessing discriminant validity in variance-based structural equation modeling. *Journal of the Academy of Marketing Science, 43*(1), 115–135. <https://doi.org/10.1007/s11747-014-0403-8>
- Isaac, O., Abdullah, Z., Ramayah, T., & Mutahar, A. M. (2017a). Internet usage, user satisfaction, task-technology fit, and performance impact among public sector employees in Yemen. *International Journal of Information and Learning Technology, 34*(3), 210–241. <https://doi.org/10.1108/IJILT-11-2016-0051>
- Isaac, O., Abdullah, Z., Ramayah, T., & Mutahar, A. M. (2017b). Internet Usage within Government Institutions in Yemen: An Extended Technology Acceptance Model (TAM) with Internet Self-Efficacy and Performance Impact. *Science International, 29*(4), 737–747. <http://journal.existentialpsychology.org/index.php/ExPsy/article/view/159>
- Isaac, O., Masoud, Y., Samad, S., & Abdullah, Z. (2016). The mediating effect of strategic implementation between strategy formulation and organizational performance within government institutions in Yemen. *Research Journal of Applied Sciences, 11*(10), 1002–1013. <https://doi.org/10.3923/rjasci.2016.1002.1013>
- Kline, R. B. (2011). *Principles And Practice Of Structural Equation Modeling* (3rd ed.). Guilford Press.
- Koehler, M. J., Mishra, P., & Cain, W. (2013). What is Technological Pedagogical Content Knowledge (TPACK)? *Journal of Education, 193*(3), 13–19. <https://doi.org/10.1177/002205741319300303>
- Koh, J. H. L., Chai, C. S., Huang, Y. H., & Tsai, C. C. (2013). Exploring the relationship between pre-service teachers' perceptions of efficacy for technological pedagogical content knowledge and efficacy for ICT design thinking. *AECT International Conference on the Frontier in E-Learning Research Taichung, Taiwan*.
- Lim, C. P., & Chan, B. C. (2007). microLESSONS in teacher education: Examining pre-service teachers' pedagogical beliefs. *Computers and Education, 48*(3), 474–494. <https://doi.org/10.1016/j.compedu.2005.03.005>
- Mishra, P., & Koehler, M. J. (2006). Technological Pedagogical Content Knowledge: A Framework for Teacher Knowledge. *Teachers College Record, 108*(6), 1017–1054. http://one2oneheights.pbworks.com/f/MISHRA_PUNYA.pdf
- Niess, M. L. (2008). Guiding preservice teachers in developing TPACK. *Handbook of Technological Pedagogical Content Knowledge (TPCK) for Educators, April*, 223–250.
- Ringle, C. M., Wende, S., & Becker, J. M. (2015). *SmartPLS 3*. SmartPLS.

- Shulman, L. (1986). Those Who Understand: A Conception of Teacher Knowledge. *American Educator*, 10(1), 4–14. <https://doi.org/10.3102/0013189X015002004>
- Shulman, L. (1987). Knowledge and Teaching: Foundations of the New Reform. *Harvard Educational Review*, 57(1), 1–23. <https://doi.org/10.17763/haer.57.1.j463w79r56455411>
- Tondeur, J., Van Braak, J., Siddiq, F., & Scherer, R. (2016). Time for a new approach to prepare future teachers for educational technology use: Its meaning and measurement. *Computers and Education*, 94, 134–150. <https://doi.org/10.1016/j.compedu.2015.11.009>
- West, S. G., Finch, J. F., & Curan, P. J. (1995). *Structural Equation Models with Non Normal Variables: Problems and remedies*. In: Hoyle, R.H., Ed., *Structural Equation Modeling: Concepts, Issues, and Applications*. Sage, Thousand Oaks.
- Yeh, Y. F., Hsu, Y. S., Wu, H. K., Hwang, F. K., & Lin, T. C. (2014). Developing and validating technological pedagogical content knowledge-practical (TPACK-practical) through the Delphi survey technique. *British Journal of Educational Technology*, 45(4), 707–722. <https://doi.org/10.1111/bjet.12078>